

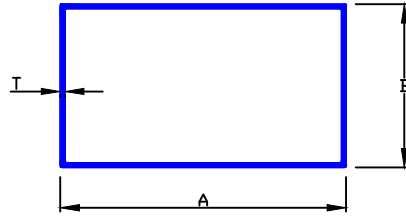

ALUMETAL INDUSTRIES

**RECT TUBE**



SEC.No.	C/L	A	B	T	WEIGHT
1001	12'	36.00	24.00	0.63	0.700-0.900
1002	12'	36.00	24.00	1.05	0.900-1.100
1003	12'	38.00	25.00	0.92	1.100-1.300
1004	12'	50.00	25.00	0.64	0.900-1.100
1005	12'	50.00	25.00	0.78	1.150-1.300
1006	12'	50.00	25.00	0.92	1.350-1.550
1007	12'	63.00	25.00	0.71	1.200-1.400
1008	12'	63.00	25.00	0.90	1.500-1.700
1009	12'	63.00	38.00	0.70	1.300-1.600
1010	12'	63.00	38.00	0.70	1.700-1.950
1011	12'	33.00	22.50	0.54	0.570-0.700
1012	12'	75.00	25.00	0.80	1.500-1.700
1013	12'	50.00	12.00	2.00	2.300-2.500
1014	12'	25.00	12.00	1.50	1.000-1.200
1015	12'	75.00	12.00	2.00	3.250-3.450
1016	12'	75.00	19.00	2.00	3.550-3.750





ALUMETAL INDUSTRIES

## SINGLE PARTITION

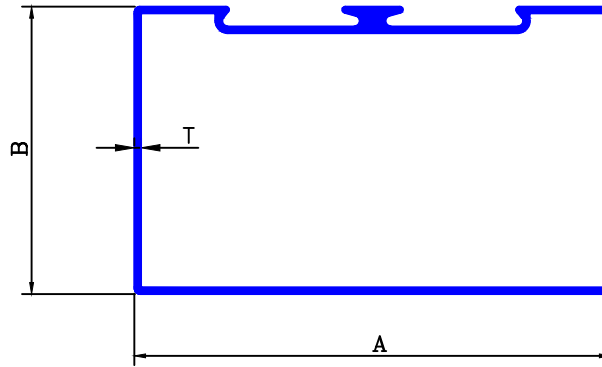

SEC.No.	C/L	A	B	T	WEIGHT
1051	15'	63.00	38.00	0.90	2.300-2.500
1052	15'	63.00	38.00	1.00	2.600-2.900
1053	15'	63.00	38.00	1.20	3.100-3.400
1054	16'	63.00	38.00	1.30	3.400-3.600
1055	16'	63.00	38.00	1.40	3.800-4.000
1056	16'	63.00	38.00	1.80	4.800-5.000
1057	16'	63.00	38.00	2.60	7.000-7.400
1058	16'	63.00	38.00	3.00	8.000-8.200



ALUMETAL INDUSTRIES

## DOUBLE PARTITION

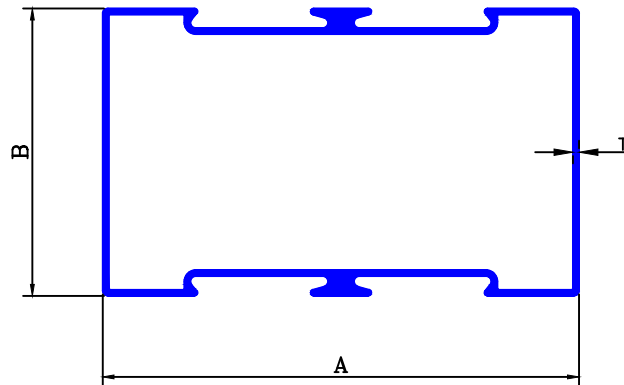

SEC.No.	C/L	A	B	T	WEIGHT
1071	15'	63.00	38.00	0.80	2.300-2.500
1072	15'	63.00	38.00	0.90	2.600-2.900
1073	15'	63.00	38.00	1.10	3.100-3.400
1074	16'	63.00	38.00	1.20	3.400-3.600
1075	16'	63.00	38.00	1.30	3.800-4.000
1076	16'	63.00	38.00	1.70	4.800-5.000
1077	16'	63.00	38.00	2.50	7.000-7.400
1078	16'	63.00	38.00	2.90	8.000-8.200



ALUMETAL INDUSTRIES

## DOOR MIDDLE SINGLE

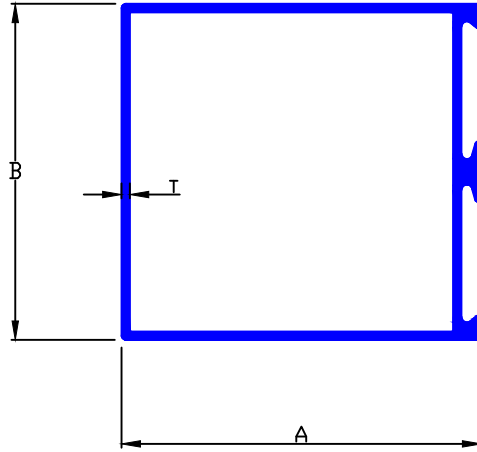

SEC.No.	C/L	A	B	T	WEIGHT
1091	15'	47.50	44.45	0.95	2.400-2.500
1092	15'	47.50	44.45	1.05	2.600-2.700
1093	15'	47.50	44.45	1.15	2.750-2.900
1094	16'	83.50	44.45	1.15	4.500-4.700



ALUMETAL INDUSTRIES

## DOOR MIDDLE DOUBLE

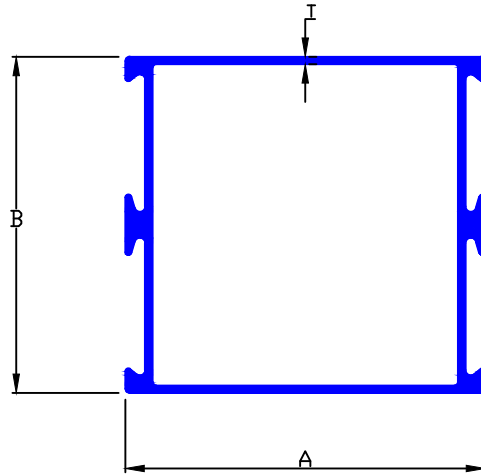

SEC.No.	C/L	A	B	T	WEIGHT
1101	15'	47.50	44.45	0.90	2.500-2.600
1102	15'	47.50	44.45	1.00	2.700-2.800
1103	15'	47.50	44.45	1.10	2.900-3.000
1104	16'	83.50	44.45	1.10	4.500-4.700



## DOOR TOP

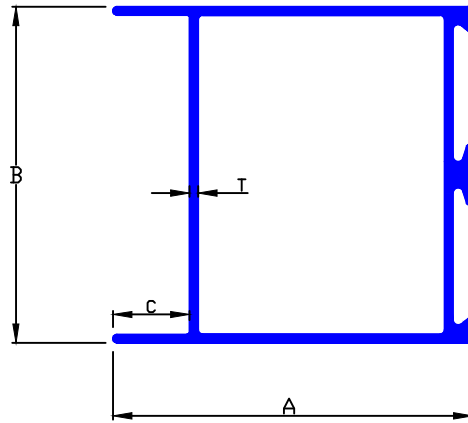

SEC.No.	C/L	A	B	C	T	WEIGHT
1111	15'	47.50	44.45	10.10	1.00	2.400-2.600
1112	15'	47.50	44.45	10.10	1.10	2.700-2.900
1113	16'	83.50	44.45	10.10	1.10	4.500-4.700

## DOOR TOP SINGLE LEG

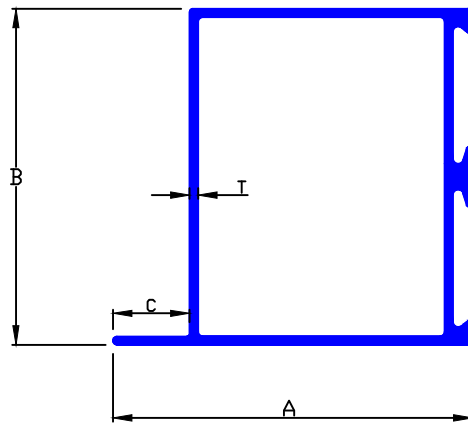

SEC.No.	C/L	A	B	C	T	WEIGHT
1121	15'	47.50	44.45	10.10	1.00	2.300-2.500
1122	15'	47.50	44.45	10.10	1.10	2.600-2.800
1123	16'	83.50	44.45	10.10	1.10	4.500-4.700



## DOOR VERTICLE

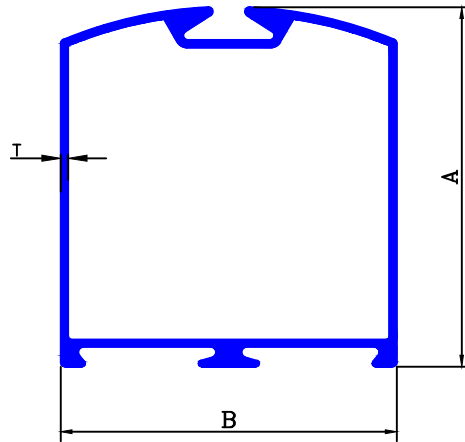

SEC.No.	C/L	A	B	C	WEIGHT
1131	15'	47.50	44.45	10.10	2.700-2.800
1132	15'	47.50	44.45	10.10	2.900-3.050
1133	16'	83.50	44.45	10.10	4.500-4.700

## STRUCTURE GLASING

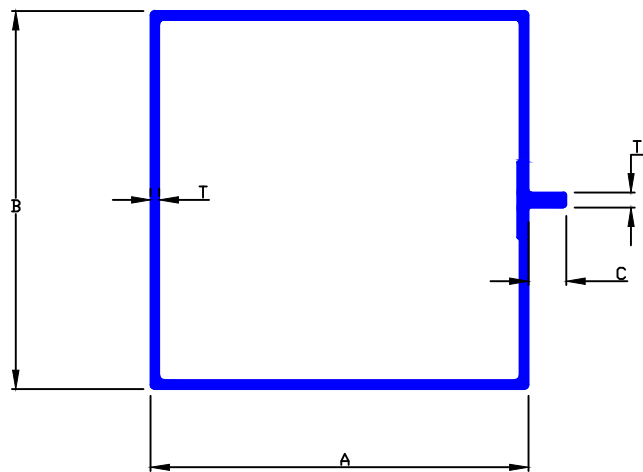

SEC.No.	C/L	A	B	C	T	T1	WEIGHT
1141	16	45.00	45.00	5.00	1.03	1.60	2.500-2.700
1142	12	50.00	50.00	5.00	1.18	2.00	2.400-2.600





### 3/4" TWO TRACK TOP

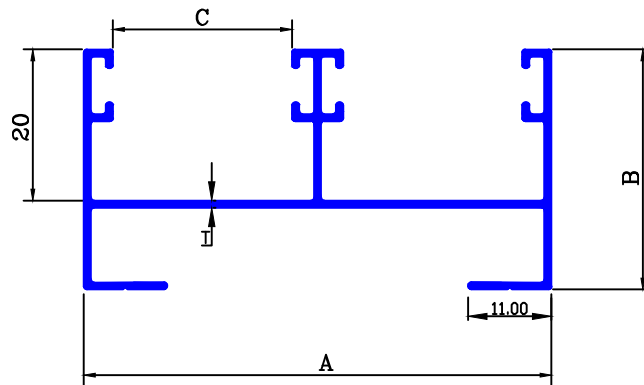

SEC.No.	C/L	A	B	C	T	WEIGHT
1151	12	61.85	31.75	23.68	0.80	1.500-1.600
1152	12	61.85	31.75	23.68	0.90	1.700-1.800
1153	16	61.85	31.75	23.68	1.00	2.500-2.800
1154	16	61.85	31.75	23.68	1.20	3.000-3.200
1155	16	61.85	31.75	23.68	1.30	3.500-3.800

### 3/4" TWO TRACK BOTTOM

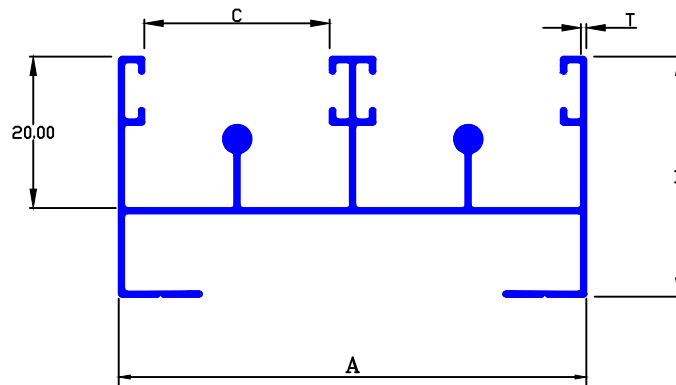

SEC.No.	C/L	A	B	C	T	WEIGHT
1161	12	61.85	31.75	24.50	0.70	1.600-1.700
1162	12	61.85	31.75	24.50	0.80	1.700-1.850
1163	16	61.85	31.75	23.68	1.25	2.500-2.800
1164	16	61.85	31.75	23.68	1.30	3.000-3.200
1165	16	61.85	31.75	23.68	1.50	3.500-3.800



ALUMETAL INDUSTRIES

### 3/4" THREE TRACK TOP

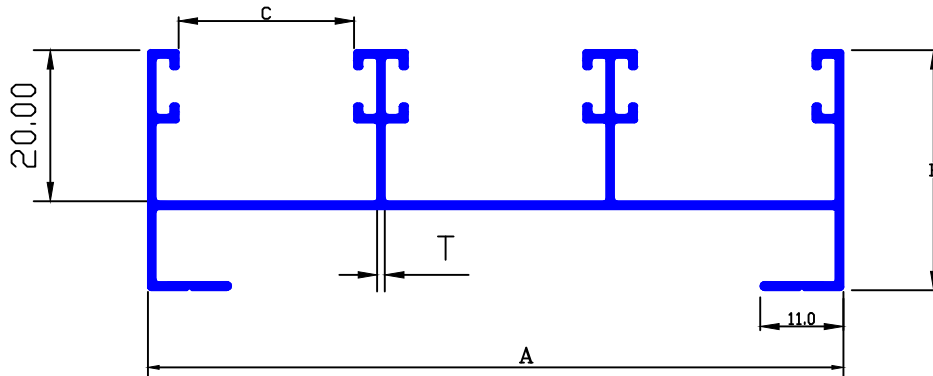

SEC.No.	C/L	A	B	C	T	WEIGHT
1171	12	92.0	31.75	23.50	1.00	2.600-2.800
1172	12	92.0	31.75	23.50	1.20	2.900-3.200

### 3/4" THREE TRACK BOTTOM

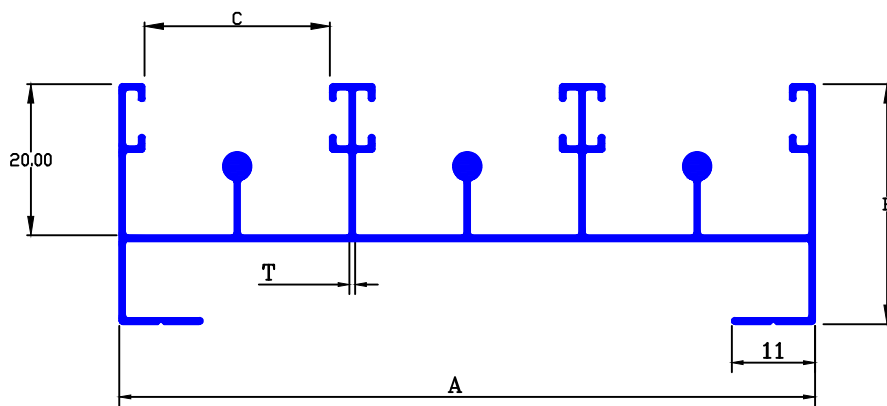

SEC.No.	C/L	A	B	C	T	WEIGHT
1181	12	92.00	31.75	24.00	0.80	2.600-2.800
1182	12	92.00	31.75	24.00	1.00	2.900-3.200



ALUMETAL INDUSTRIES

### 3/4" HANDLE

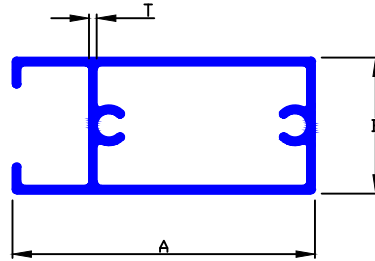

SEC.No.	C/L	A	B	T	WEIGHT
1191	12	40.00	18.00	0.57	0.800-0.900
1192	12	40.00	18.00	0.72	0.950-1.100
1193	12	40.00	18.00	0.90	1.150-1.300
1194	12	40.00	18.00	1.20	1.600-1.800
1195	12	40.00	18.00	1.50	2.000-2.200
1196	12	40.00	18.00	2.00	2.700-2.900

### 3/4" INTERLOCK

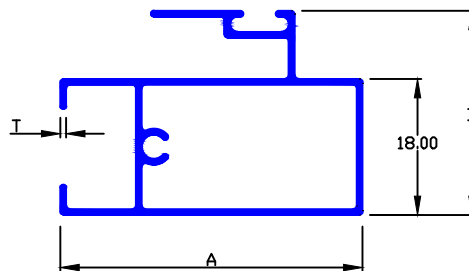

SEC.No.	C/L	A	B	T	WEIGHT
1201	12	40.00	27.00	0.70	1.100-1.250
1202	12	40.00	27.00	0.84	1.350-1.550
1203	12	40.00	27.00	1.20	1.900-2.100
1204	12	40.00	27.00	1.50	2.400-2.600



# ALUMETAL INDUSTRIES

## 3/4" TOP BOTTOM

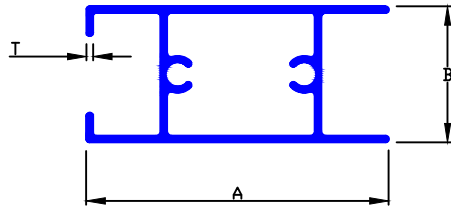

SEC.No.	C/L	A	B	T	WEIGHT
1211	12	40.00	18.00	0.57	0.800-0.950
1212	12	40.00	18.00	0.80	1.050-1.150
1213	12	40.00	18.00	0.90	1.200-1.400
1214	12	40.00	18.00	1.20	1.600-1.800
1215	12	40.00	18.00	1.50	2.000-2.200
1216	12	40.00	18.00	2.00	2.700-2.900

## BEARING BOTTOM

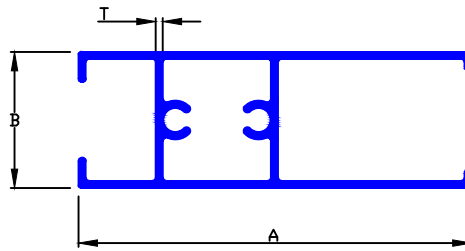

SEC.No.	C/L	A	B	T	WEIGHT
1221	12	52.00	18.00	0.80	1.300-1.400
1222	12	52.00	18.00	0.90	1.450-1.600

## MATTING

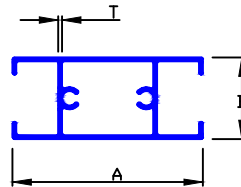

SEC.No.	C/L	A	B	T	WEIGHT
1231	12'	42.00	18.00	0.70	1.000-1.150
1232	12'	42.00	18.00	0.85	1.200-1.400
1233	12'	42.00	18.00	1.20	1.600-1.800
1234	12'	42.00	18.00	1.50	2.000-2.200
1235	12'	42.00	18.00	2.00	2.700-2.900



### 3/4" 2 TRACK TOP WITH PARTITION

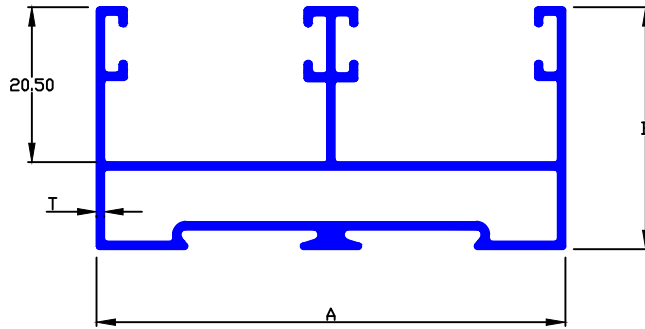

SEC.No.	C/L	A	B	T	WT. RANGE
1241	16'	62.00	32.00	1.01	2.600-2.800

### 3/4" 2 TRACK BOTTOM WITH PARTITION

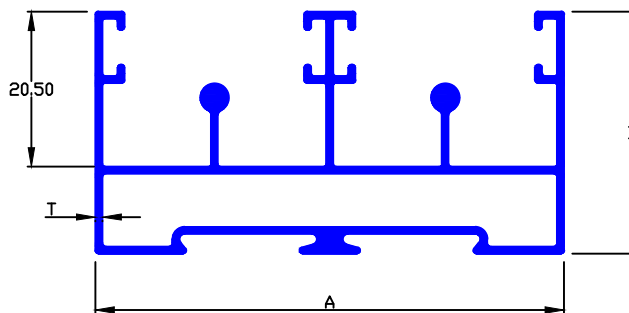

SEC.No.	C/L	A	B	T	WT. RANGE
1246	12'	62.00	32.00	0.92	2.700-2.900



## GLAZING CLIP

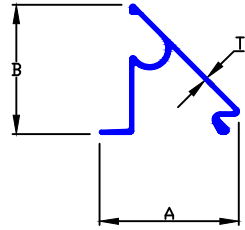

SEC.No.	C/L	A	B	T	WEIGHT
1251	12	18.40	17.00	0.52	0.240-0.260
1252	12	18.40	17.00	0.60	0.260-0.280
1253	12	18.40	17.00	0.38	0.180-0.200
1254	12	18.40	17.00	0.45	0.210-0.230
1255	12	18.40	17.00	0.55	0.350-0.400

## GLAZING PLATE

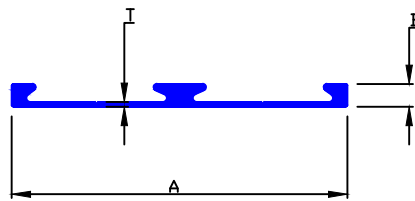

SEC.No.	C/L	A	B	T	WEIGHT
1261	12	44.00	3.40	0.69	0.500-0.600
1262	12	44.00	3.40	0.78	0.600-0.700



ALUMETAL INDUSTRIES

## 20 mm TWO TRACK TOP

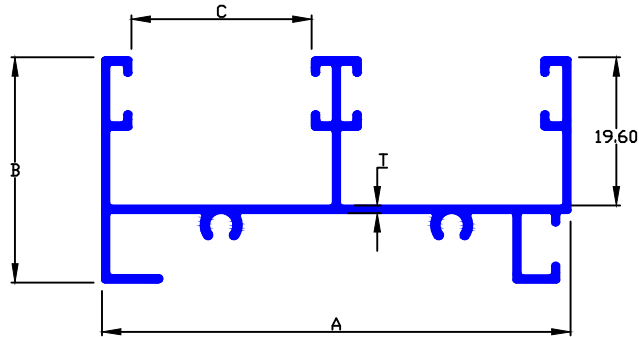

SEC.No.	C/L	A	B	C	T	WEIGHT
1271	16	62.00	29.50	23.80	0.70	2.100-2.200
1272	16	62.00	29.50	23.80	0.85	2.400-2.600
1273	16	62.00	29.50	23.80	0.90	2.600-2.800
1274	16	62.00	29.50	23.80	0.95	2.800-3.000
1275	16	62.00	29.50	23.80	1.20	3.800-4.000

## 20 mm TWO TRACK BOTTOM

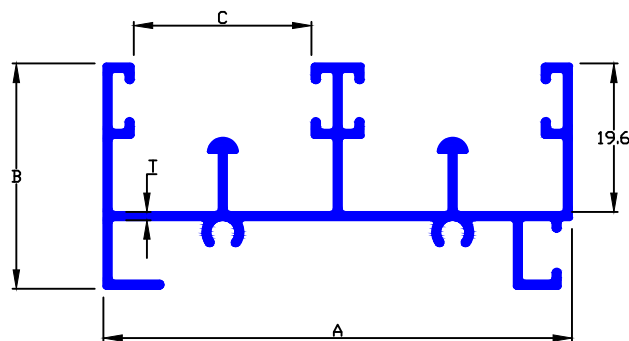

SEC.No.	C/L	A	B	C	T	WEIGHT
1281	16	62.00	29.50	23.80	0.72	2.300-2.450
1282	16	62.00	29.50	23.80	0.80	2.450-2.650
1283	16	62.00	29.50	23.40	0.90	2.800-3.100
1284	16	62.00	29.50	23.80	0.80	2.600-2.800
1285	16	62.00	29.50	23.80	1.15	3.800-4.000



## 20 mm THREE TRACK TOP

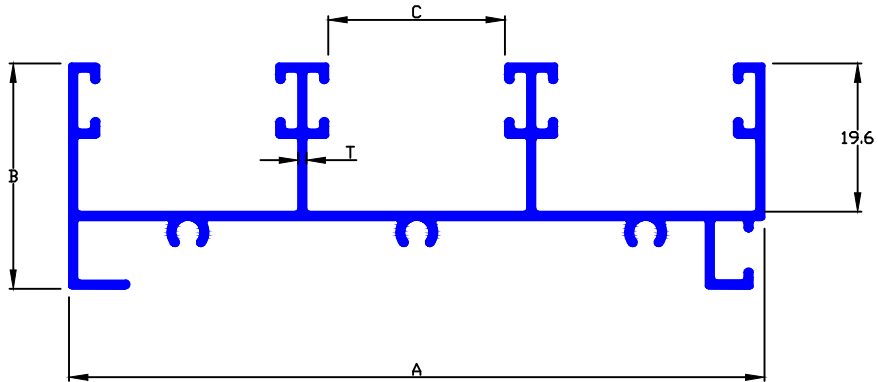

SEC.No.	C/L	A	B	C	T	WEIGHT
1291	16	92.00	29.50	23.50	0.72	2.800-3.100
1292	16	92.00	29.50	23.50	0.83	3.100-3.400
1293	16	92.00	29.50	23.50	0.95	3.600-3.800
1294	16	92.00	29.50	23.50	1.05	3.800-4.000
1295	16	92.00	29.50	23.50	1.20	4.800-5.200

## 20 mm THREE TRACK BOTTOM

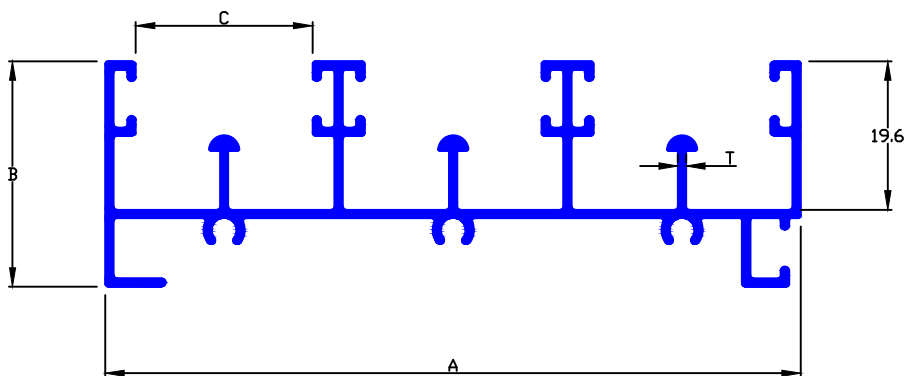

SEC.No.	C/L	A	B	C	T	WEIGHT
1301	16	92.00	29.50	23.50	0.70	3.300-3.800
1302	16	92.00	29.50	23.50	1.00	3.800-4.000
1303	16	92.00	29.50	23.50	1.20	4.800-5.200





# ALUMETAL INDUSTRIES

## 20mm HANDLE

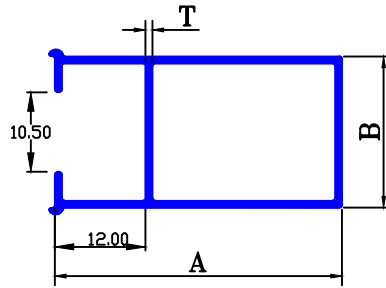

SEC.No.	C/L	A	B	T	WEIGHT
1311	16	38.00	20.00	0.79	1.300-1.500
1312	12	38.00	20.00	0.92	1.100-1.300
1313	12	38.00	20.00	1.00	1.200-1.400
1314	16	38.00	20.00	0.90	1.800-2.000
1315	16	38.00	20.00	0.95	2.000-2.200
1316	16	38.00	20.00	1.20	2.400-2.600

## 20mm INTERLOCK

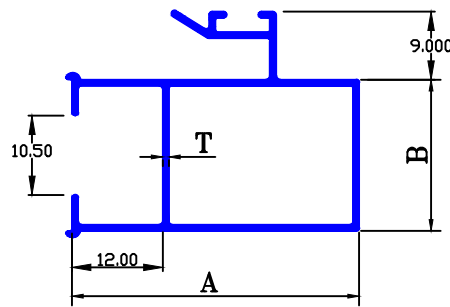

SEC.No.	C/L	A	B	T	WEIGHT
1321	16	38.00	20.00	0.69	1.400-1.600
1322	12	38.00	20.00	0.82	1.200-1.400
1323	12	38.00	20.00	1.20	1.700-1.900

## 20mm TOP BOTTOM

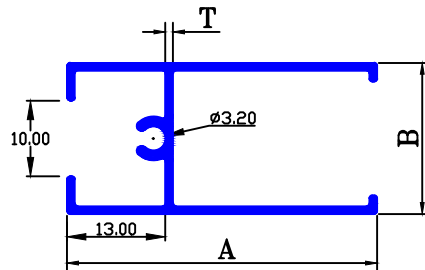

SEC.No.	C/L	A	B	T	WEIGHT
1331	12	41.00	20.00	0.85	1.000-1.200
1332	12	41.00	20.00	1.50	1.700-1.900



ALUMETAL INDUSTRIES

## 1" HANDLE

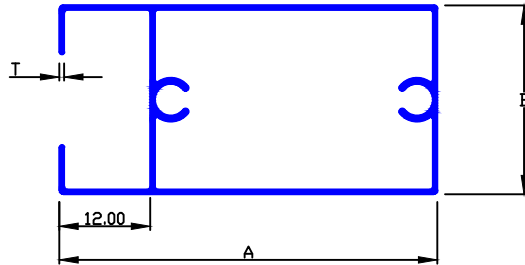

SEC.No.	C/L	A	B	T	WEIGHT
1341	12'	50.00	25.00	0.62	1.100-1.300
1342	12'	50.00	25.00	0.75	1.350-1.550
1343	12'	50.00	25.00	0.85	2.700-3.000
1344	12'	50.00	25.00	0.95	1.600-1.800
1345	12'	50.00	25.00	1.10	2.000-2.200
1346	12'	50.00	25.00	1.20	2.500-2.700

## 1" INTERLOCK

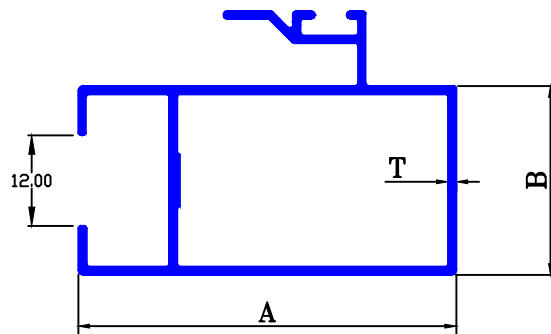

SEC.No.	C/L	A	B	T	WEIGHT
1351	12	50.00	25.00	1.10	2.000-2.100



# ALUMETAL INDUSTRIES

## 1" TOP BOTTOM

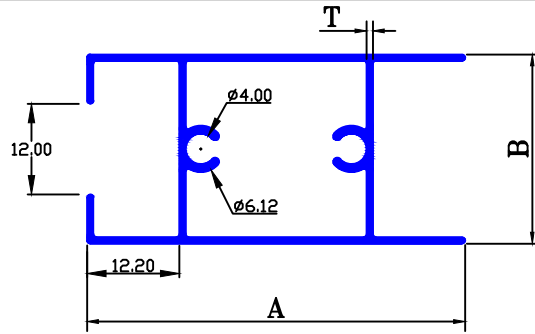

SEC.No.	C/L	A	B	T	WEIGHT
1361	12	45.00	25.00	0.62	1.100-1.300
1362	12	50.00	25.00	0.77	1.350-1.550
1363	12	50.00	25.00	0.95	1.600-1.800
1364	12	50.00	25.00	1.10	2.000-2.200
1365	12	50.00	25.00	1.20	2.500-2.700

## BEARING BOTTOM

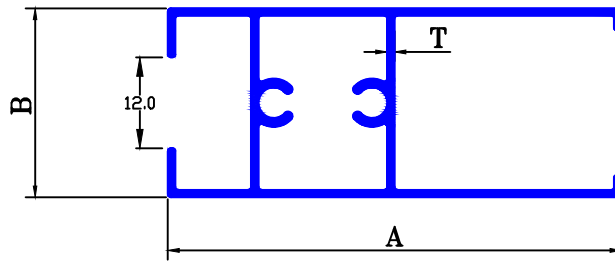

SEC.No.	C/L	A	B	T	WEIGHT
1371	12'	60.00	25.00	1.00	2.000-2.200

## MATTING

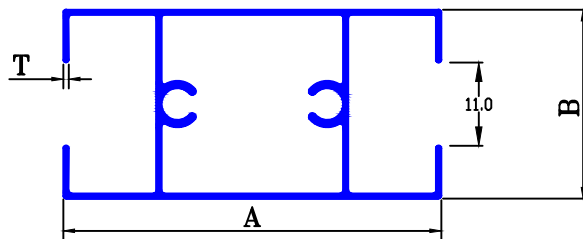

SEC.No.	C/L	A	B	T	WEIGHT
1381	12'	50.00	25.00	0.60	1.200-1.350
1382	12'	50.00	25.00	0.70	1.400-1.600
1383	16'	50.00	25.00	0.95	1.600-1.800
1384	16'	50.00	25.00	1.10	2.000-2.200
1385	16'	50.00	25.00	1.20	2.500-2.700



### L-TUBE

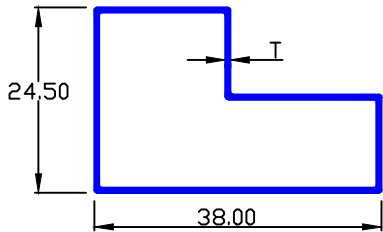

SEC.No.	C/L	T	WEIGHT
1391	12	0.67	0.800-0.950
1392	12	0.85	1.000-1.200

### 'L' TUBE WITH GROOVE

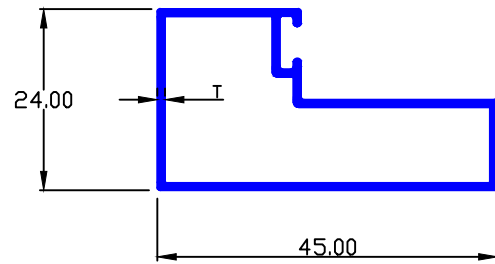

SEC.No.	C/L	T	WEIGHT
1401	12	1.00	1.350-1.500

### 2 1/2 X 1 1/2 L-TUBE

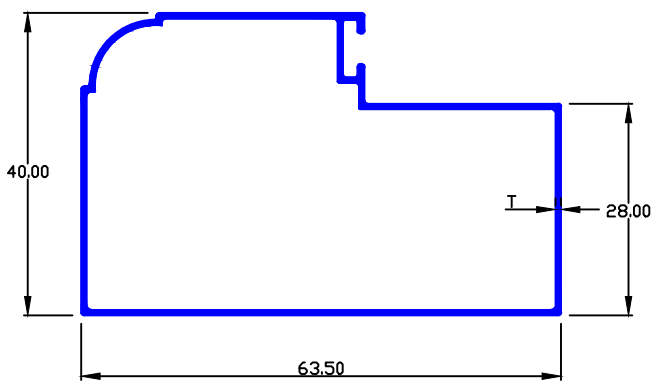

SEC.No.	C/L	T	WEIGHT
1411	12	0.74	1.500-1.700
1412	16	0.80	2.200-2.400
1413	16	0.95	2.500-2.700
1414	16	1.10	2.800-3.000
1415	16	1.20	3.000-3.200

### CORNER PARTITION

SEC. NO:- 1421

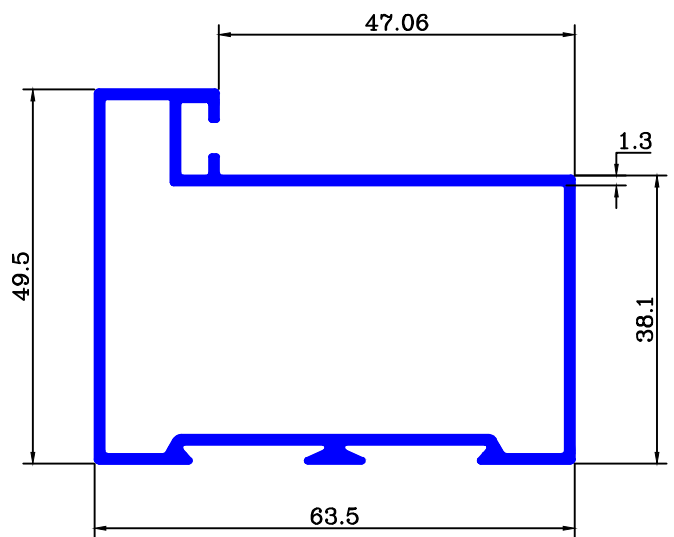

WEIGHT:- 3.200-3.400 kg/12'



ALUMETAL INDUSTRIES

## PROFILE L-TUBE

SEC. NO:-1431

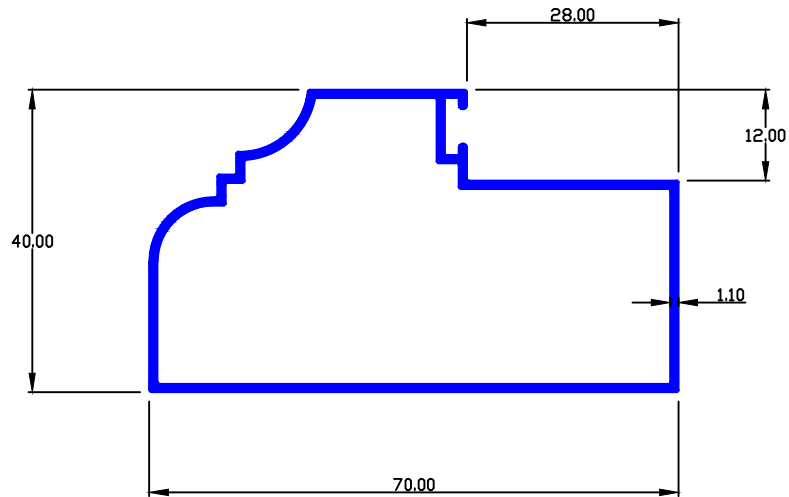

WEIGHT:- 2.300-2.500 kg/12'

## 3" X 1" MATTING

SEC. NO:-1441

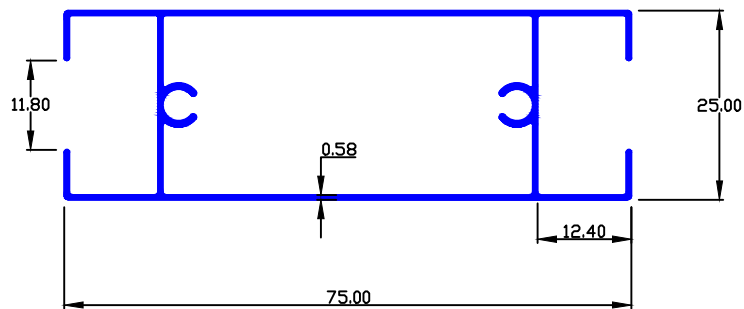

WEIGHT:- 1.400-1.600 kg/12'



ALUMETAL INDUSTRIES

## MOULDING HANDLE

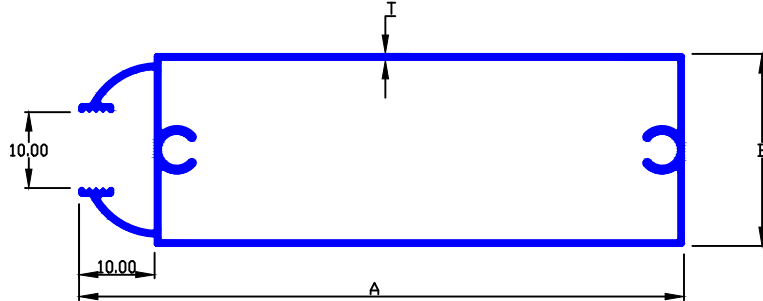

SEC.No.	C/L	A	B	T	WT. RANGE
1451	16'	60.00	25.40	0.75	2.100-2.300
1452	16'	60.00	25.40	0.86	2.400-2.600
1453	16'	80.00	25.40	0.65	2.200-2.400
1454	16'	80.00	25.40	0.76	2.400-2.700
1455	16'	80.00	25.40	0.86	2.800-3.100

## MOULDING MATTING

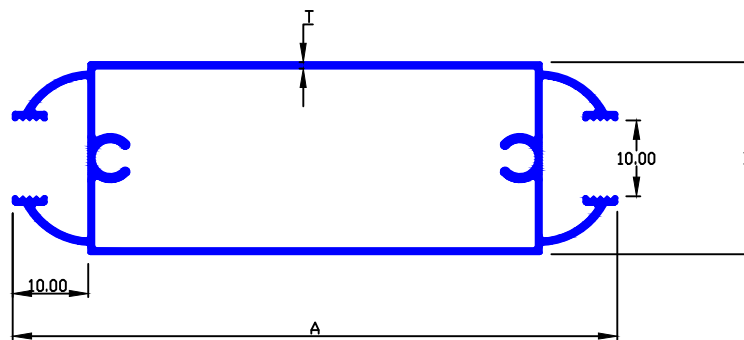

SEC.No.	C/L	A	B	T	WT. RANGE
1461	16'	60.00	25.40	0.75	2.200-2.400
1462	16'	80.00	25.40	0.63	2.200-2.400
1463	16'	80.00	25.40	0.82	2.800-3.100



## MOULDING TOP BOTTOM

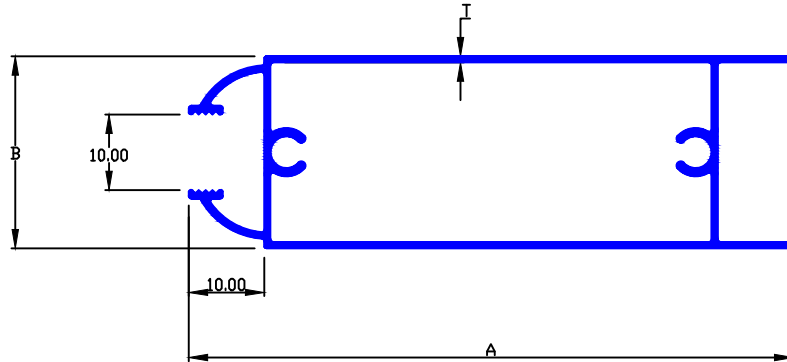

SEC.No.	C/L	A	B	T	WT. RANGE
1471	16'	60.00	25.40	0.80	2.200-2.400
1472	16'	80.00	25.40	0.80	2.700-3.000

## MOULDING TOP BOTTOM ( S.L.)

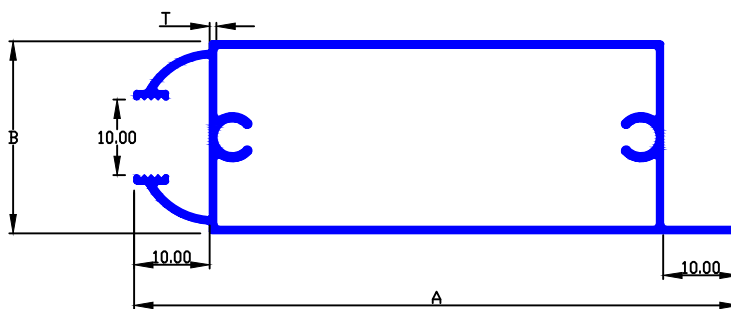

SEC.No.	C/L	A	B	T	WT. RANGE
1481	16'	60.00	25.40	0.80	2.200-2.400
1482	16'	80.00	25.40	0.85	2.700-3.000



## HANDLE (RADIUS)

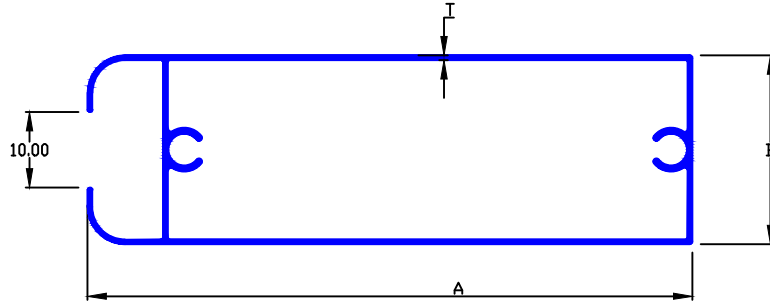

SEC.No.	C/L	A	B	T	WT. RANGE
1491	12'	80.00	25.00	0.60	1.300-1.500
1492	16'	80.00	25.00	0.80	2.300-2.500
1493	16'	80.00	25.00	1.00	2.700-3.000

## MATTING (RADIUS)

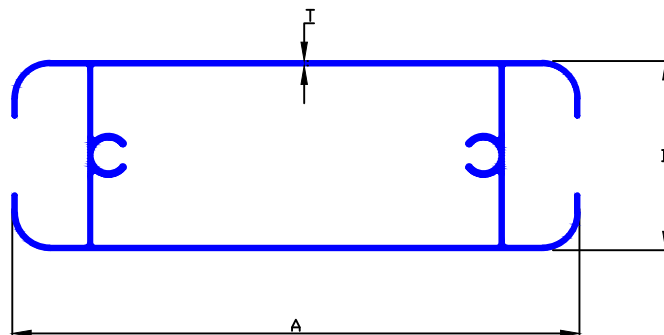

SEC.No.	C/L	A	B	T	WT. RANGE
1501	16'	75.00	25.00	0.56	1.300-1.500
1502	16'	75.00	25.00	0.80	2.300-2.500
1503	16'	75.00	25.00	1.00	2.700-3.000





ALUMETAL INDUSTRIES

### 3" X 1" HANDLE

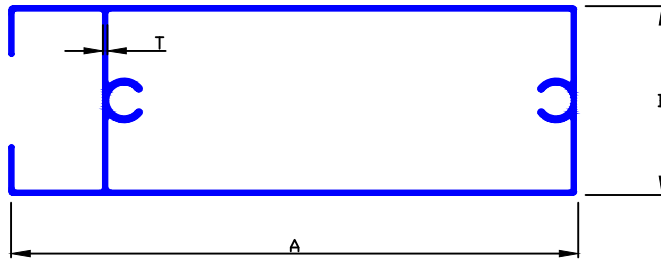

SEC.No.	C/L	A	B	T	WT. RANGE
1511	12'	75.00	25.00	0.59	1.400-1.600



ALUMETAL INDUSTRIES

### DUMAL 2 TRACK

SEC. NO:-1521

SECTION NO:- AI-102

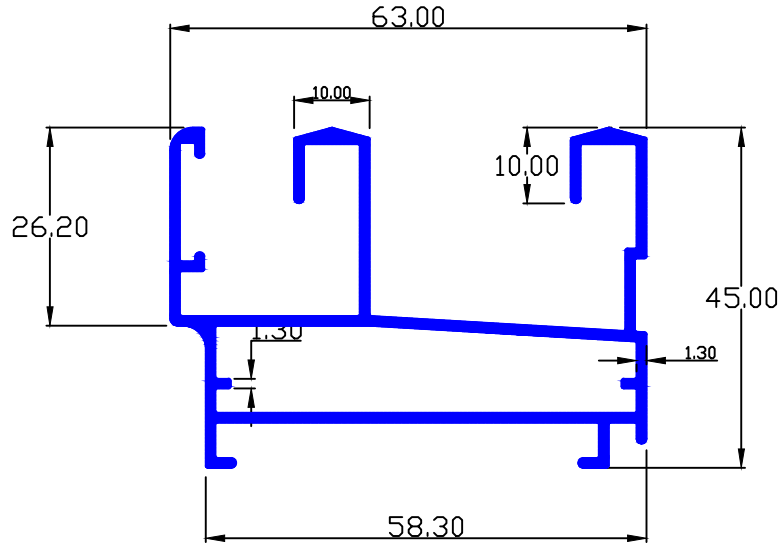

WEIGHT:- 3.700-3.900 kg/12'

### DUMAL 3 TRACK

SEC. NO:-1531

SECTION NO:- AI-101

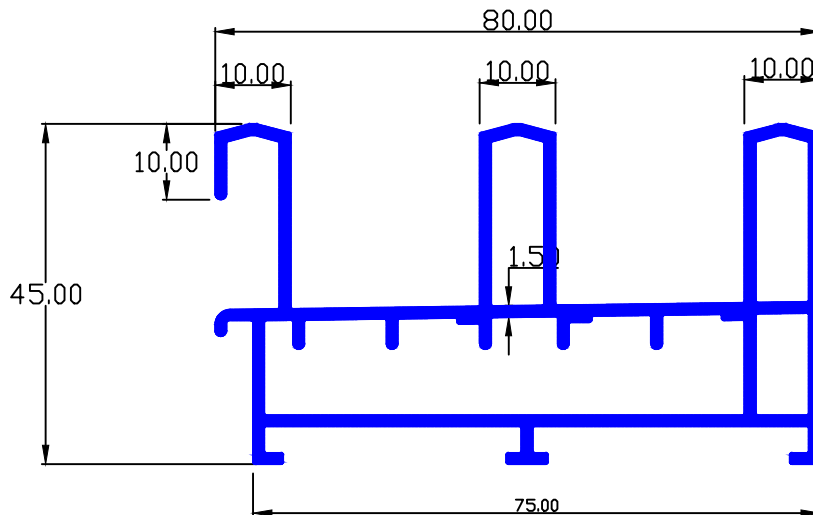

WEIGHT:- 6.700-6.900 kg/12'



ALUMETAL INDUSTRIES

### DUMAL 3 TRACK

SEC. NO:-1541

SECTION NO:- AI-26

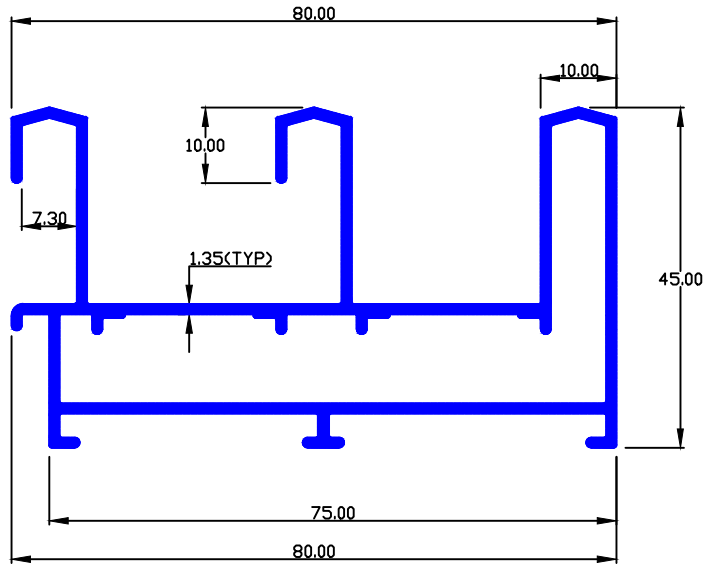

WEIGHT:- 6.200-6.400 kg/12'

### DUMAL 2 TRACK

SEC. NO:-1551

SECTION NO:- AI-25

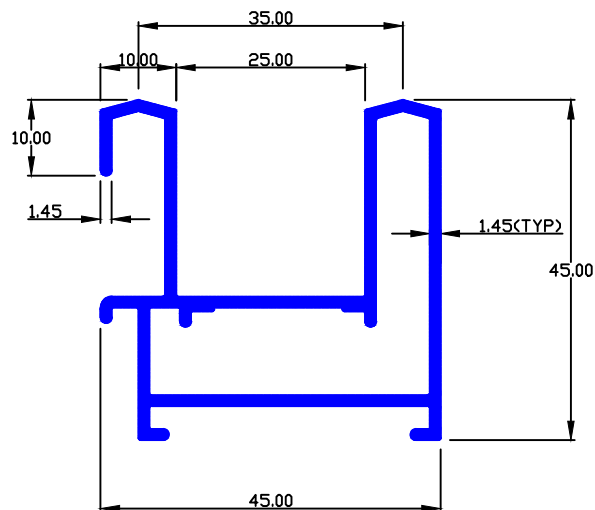

WEIGHT:- 4.200-4.400 kg/12'



ALUMETAL INDUSTRIES

## DUMAL CLIP

SEC. NO:-1561

SECTION NO:- AI-106

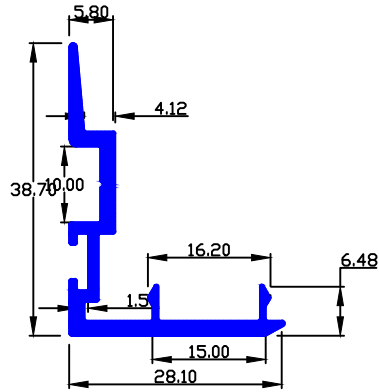

WEIGHT:- 1.400-1.600 kg/12'

## DUMAL CLIP

SEC. NO:-1571

SECTION NO:- AI-28

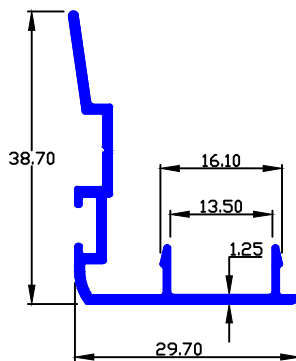

WEIGHT:- 1.400-1.600 kg/12'



ALUMETAL INDUSTRIES

### DUMAL SHUTTER

SEC. NO:-1581

SECTION NO:- AI-208

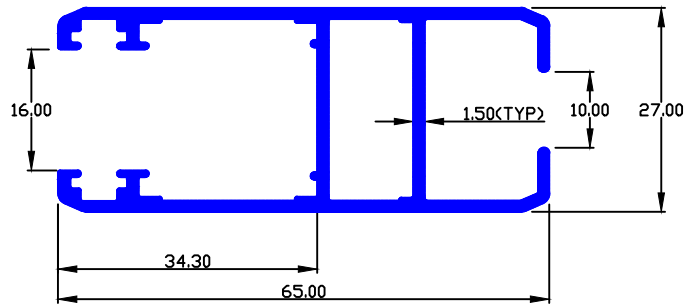

WEIGHT:- 3.200-3.400 kg/12'

### DUMAL SHUTTER

SEC. NO:-1591

SECTION NO:- AI-103

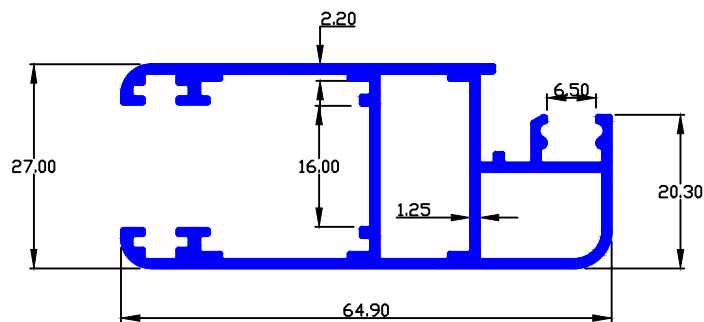

WEIGHT:- 4.900-5.100 kg/12'